

TECHNICAL CHARACTERISTICS

AHARETD

Hari

Armchair

Hari armchair, inspired by the world of textile looms, with a very industrial aesthetic combined with the delicacy of the threads to create a subtle and elegant chair.

DESIGNED BY ESTUDIOHAC



ondarreta

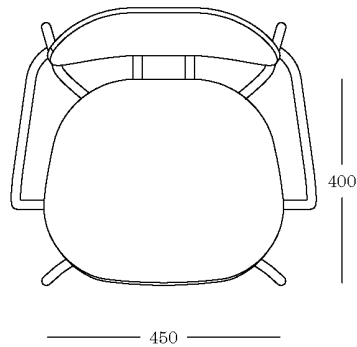
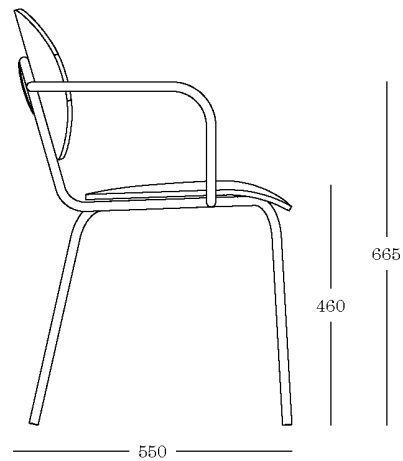
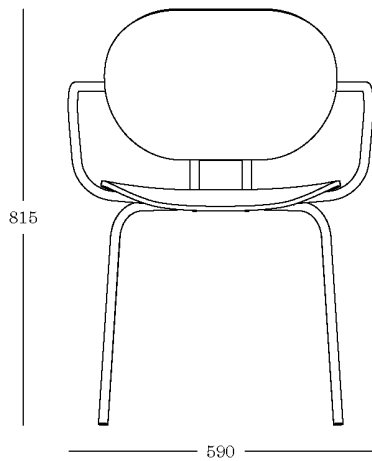

DIMENSIONS

59 cm x 55 cm x 81,5 cm x 46 x
66,5 cm [width x depth x height
x seat height x arm height]

WEIGHT

7,5 kg (16.53 lb.)

PACKAGING

One chair per box.

Box dimensions :

70 cm x 65 cm x 98,5 cm (27,6" x
25,6" x 38,8")

CERTIFICATION

Designed in accordance with the
Ecodesign standard UNE-EN ISO
14006:2011.

Product tested under the European
standard EN 16139:2013, category of
general use L2.

ACCESORIES

Felt glides (black)

OPTION

Exterior

ORIGIN

100% Made in Europe

DESIGN

Estudi{h}ac



COMPONENTS

FRAME

Material

18 mm (0.7") side and 2 mm (0.08") thickness cold laminated E-220 quality (EN-10305 Normative) steel tube.

Tensile Strength > 310 N/mm² (44,960 psi);

Elastic Limit > 220 N/mm² (31,900 psi); Elongation > 23%

Finish

Colour epoxy, for the outdoor option epoxy color with outdoor coating treatment.

SEAT

Oak

Oak wood on Beech plywood, 10 mm (0.4") thick. It's made with especially treated sheets, glued, pressed and CNC machined.

Fabrics

10 mm (0.4") thick Beech plywood. It's made with especially treated sheets, glued, pressed and CNC machined.

Exclusive and unique upholstery system that allows the fabric a perfect adherence to the seat, maintaining the own chair's shape. Medium density polyether stuffing foam.

Textured polypropylene

Textured matt copolymer. Very good mechanical properties, light and UV ray resistant.

Check for fireproofing

Density (s / ISO 1183): 900 kg / m³

Yield stress (s / ISO 527-1 / -2): 23 N / mm²

Flexural modulus (s / ISO 178): 1100 N / mm² (23 ° C)

Finish

Stained oak, fabric, matt textured polypropylene.

BACK

Beech

Beech plywood, 10 mm (0.4") thick. It's made with especially treated sheets, glued, pressed and CNC machined.

Oak

Oak wood on Beech plywood, 10 mm (0.4") thick. It's made with especially treated sheets, glued, pressed and CNC machined.



Fabrics

10 mm (0.4") thick Beech plywood. It's made with especially treated sheets, glued, pressed and CNC machined.

Exclusive and unique upholstery system that allows the fabric a perfect adherence to the back, maintaining the own chair's shape. Medium density polyether stuffing foam.

Textured polypropylene

Textured matt copolymer. Very good mechanical properties, light and UV ray resistant.

Check for fireproofing

Density (s / ISO 1183): 900 kg / m³

Yield stress (s / ISO 527-1 / -2): 23 N / mm²

Flexural modulus (s / ISO 178): 1100 N / mm² (23 ° C)

Finish

Stained beech, stained oak, fabric, matt textured polypropylene.

BUTTON

Material

Zamak material button; base metal of zinc, aluminium and copper alloy.

Complying with ISO 301-81, s/n UNE-EN-1774.

Finish

Colour epoxy (the same as the frame), for the outdoor option epoxy color with outdoor coating treatment.

METAL FINISHES

EPOXYS

Powder covering formulated with polyester resins, with good both mechanical and chemical properties, outdoor maximum resistance and noxious compounds free. Electrostatic application and oven cured at 200°C (392°F). Treatment option for outdoor protection.

Technical characteristics:

Thickness (ISO 2360): between 60 and 90 µm.

Adherence (ISO 2409): Grade: 0 (maximum adherence)



WOOD FINISHES – BACK

STAIN

Pigmented enamel with a transparent stain coating.
Reactive drying paints: excellent adherence between layers and better mechanical resistance.

Technical characteristics:

Satisfying UNE-EN 71-3 normative; Formaldehyde free compounds.

COM REQUIREMENTS

Seat fabric: 50 cm (19,7")

Full fabric (seat + back): 90 cm (35,4")